

# PIP Fix™ Condensed Surgical Guide

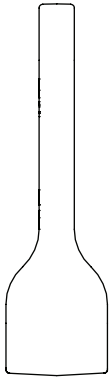

*Pin Cut Off Spacer*

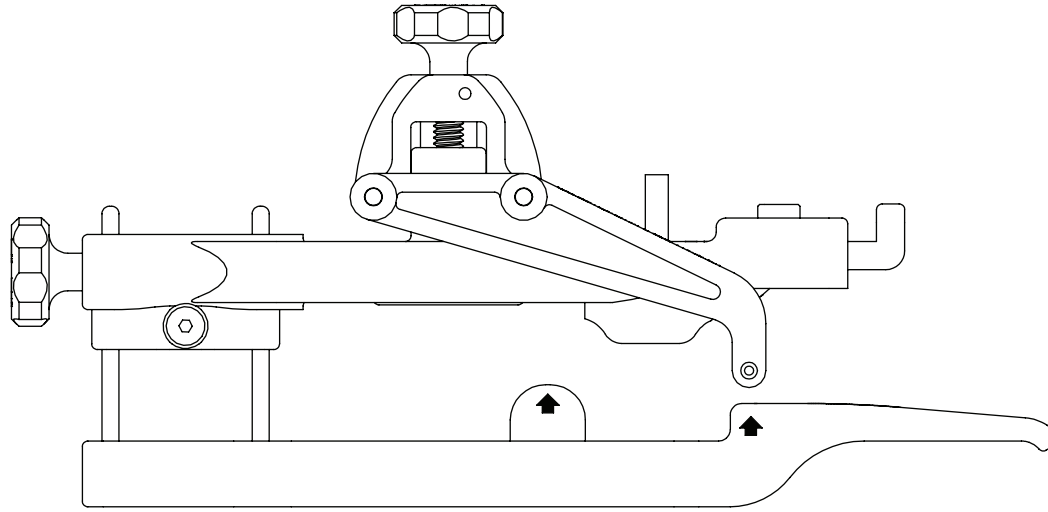

*Pin Placement Guide*

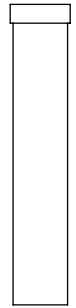

*Pin Caps*



*Transverse Pin*

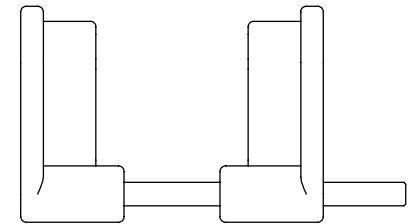

*Pin Cap Applicator*

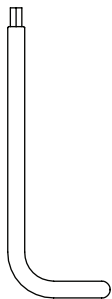

*Hex Wrench*

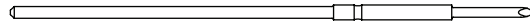

*Dorsal Pre-Drill*

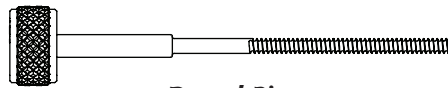

*Dorsal Pin*

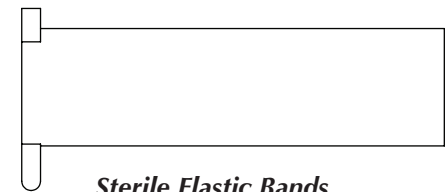

*Sterile Elastic Bands*

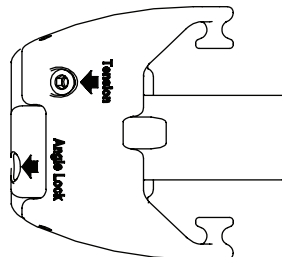

**PIP Fix**

This **CONDENSED SURGICAL GUIDE** is meant as a reminder only. Prior to use, study the Surgeon's Manual to become completely familiar with using the **PIP Fix**.

## Positioning the Pin Placement Guide (PPG)

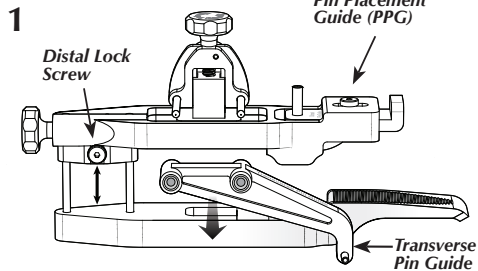

Remove the Transverse Pin Guide from its posts on the Pin Placement Guide (PPG). Loosen the Distal Lock Screw with the Hex Wrench and slide the dorsal and palmar halves apart to facilitate finger insertion. If manual reduction of the joint is not possible, the surgeon must determine the optimal Transverse Pin location based on the relevant alignment of the soft tissues with the skeletal bones.

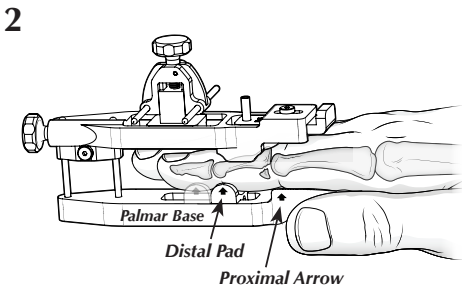

Place finger onto the Palmar Base. The palm of the hand must be parallel with the Palmar Base. Do NOT try to align the fingernail with the Palmar Base by rotating the finger on the base. Position the finger with the PIP flexion crease aligned with the proximal arrow on the Palmar Base. Slide the Distal Pad until the distal arrow aligns with the DIP flexion crease.

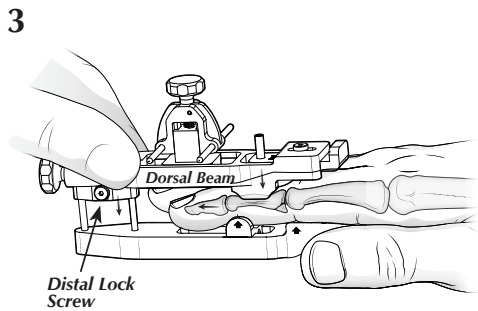

Apply manual traction to the finger as you gently clamp the finger into the PPG. Reduce the subluxed joint by lowering the Dorsal Beam onto the finger. Lock the Distal Lock Screw to maintain joint reduction.

Use fluoroscopy to confirm joint and fracture reduction.

**WARNING:** The dislocation must be reduced with the PIP joint extended to ensure the Transverse Pin is inserted palmar to the lateral bands.

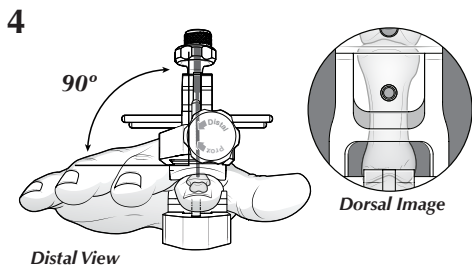

Set the Dorsal Pin into the Dorsal Drill Guide. Check the orientation of the PPG on the finger by viewing it from the distal end of the guide. The Pin should appear perpendicular to the plane of the fingers. Remove the pin from the guide. Next ensure the pin will be inserted into the center of the middle phalanx by viewing the radial ulnar position of the Dorsal Drill Guide from the top of the hand. The guide tube should be centered on the width of the middle phalanx.

Loosen the Dorsal Lock Screw with the Hex Wrench and slide the Dorsal Drill Guide proximal or distal, as needed, to ensure the Dorsal Pin will be placed slightly proximal to the mid shaft of the middle phalanx. Lock the Dorsal Drill Guide by tightening the Dorsal Lock Screw.

**WARNING:** Use fluoroscopy to determine that the Dorsal Pin will be inserted distal to the fracture site prior to pre-drilling!

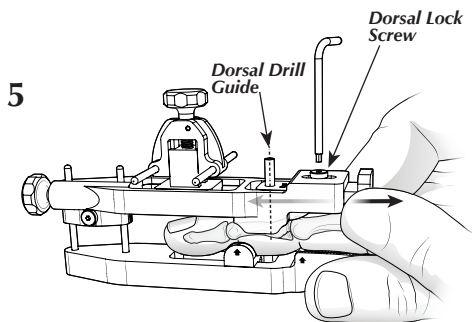

## Placement of the Bone Pins

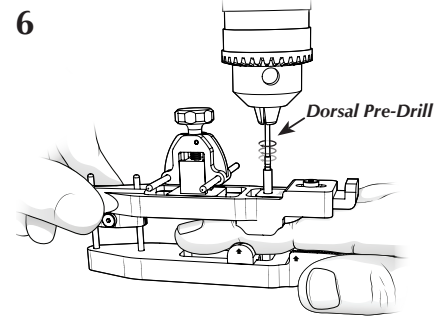

Using a power drill and fluoroscopic control, insert the Dorsal Pre-Drill through both cortices of the middle phalanx. The Pre-Drill should extend through, but not beyond, the palmar cortex.

Keeping the Drill Guide aligned with the pre-drilled hole, remove the Dorsal Pre-Drill from the bone. Maintain Drill Guide alignment with the finger until completion of the next step.

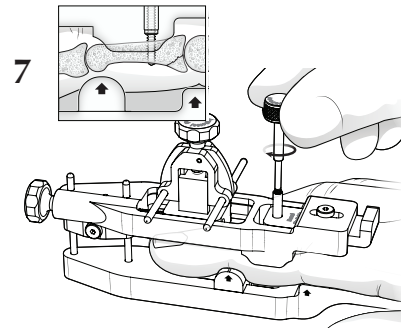

Manually thread the Dorsal Pin into the middle phalanx by rotating it clockwise into the pre-drilled hole.

The threads should extend through, but not beyond, the palmar cortex of the middle phalanx. The pin should stop short of the flexor tendons. Confirm pin depth with fluoroscopy.

1.7 rotations of pin knob = 1 mm advancement  
10 rotations of pin knob = 6 mm advancement

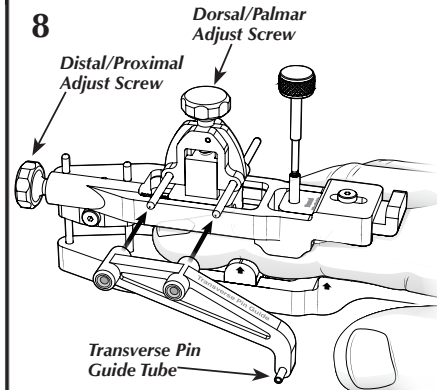

Place the Transverse Pin Guide onto the PPG on the side (radial or ulnar) that is technically easiest for pin insertion.

Use the Distal/Proximal and the Dorsal/Palmar Adjust Screws with fluoroscopic control to align the metal Transverse Pin Guide Tube at a point dorsal and proximal to the center of the head of the proximal phalanx. (See Step 9)

Slide the Transverse Pin Guide Tube snug against the skin before obtaining a final lateral fluoroscopic view centered on the tube axis to confirm the optimal position for the Transverse Pin.

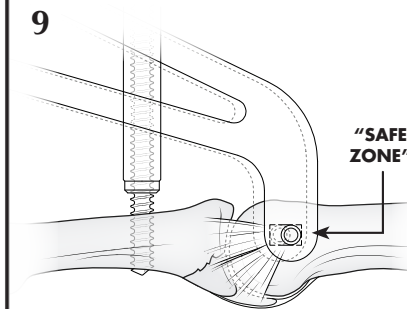

When the Transverse Pin Guide Tube is properly aligned, the Transverse Bone Pin will be inserted dorsal and proximal to the axis of rotation.

If the joint is unable to reduce, use best judgement to determine the optimal Transverse Pin location

based on the relevant alignment of the soft tissues with the skeletal bones.

1 rotation of Adjust Screw = 0.8 mm  
10 rotations of Adjust Screw = 8 mm

## Placement of the Bone Pins—Continued

10

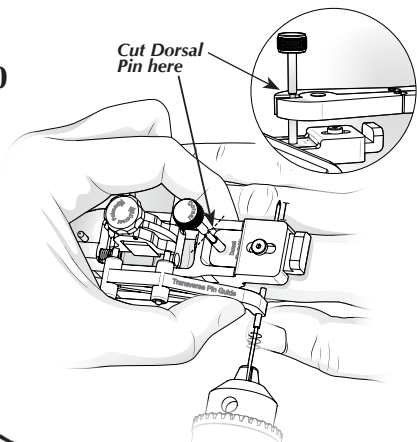

Using a power drill, insert the Transverse Pin through the head of the proximal phalanx until approximately 1 cm of the pin extends out of the skin on the far side. Holding the Transverse Pin Guide snugly against the skin when drilling will help maintain correct pin position.

Cut the Dorsal Pin just below its shoulder to allow for PPG removal. The pin must be trimmed to final length after removal of the PPG.

**CAUTION:** Confirm correct Dorsal Pin depth using fluoroscopy prior to cutting off pin.

11

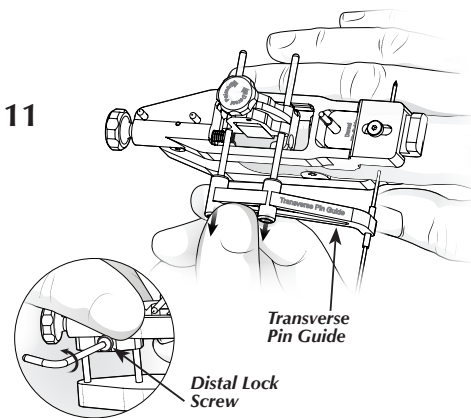

Remove the Transverse Pin Guide from the PPG.

Loosen the Distal Lock Screw and remove the PPG from the finger.

## Installation of the PIP Fix

12

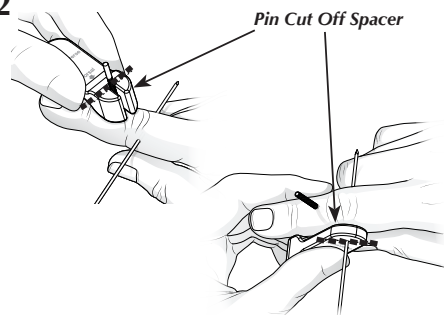

Place the thick end of the Pin Cut Off Spacer marked "Dorsal" over the Dorsal Pin and against the dorsal skin of the patient's finger. Cut the Dorsal Pin off flush with the Spacer.

Place the thin end of the Pin Cut Off Spacer marked "Transverse" over one end of the Transverse Pin and cut the pin off flush with the Spacer. Repeat on the opposite side of the finger.

13

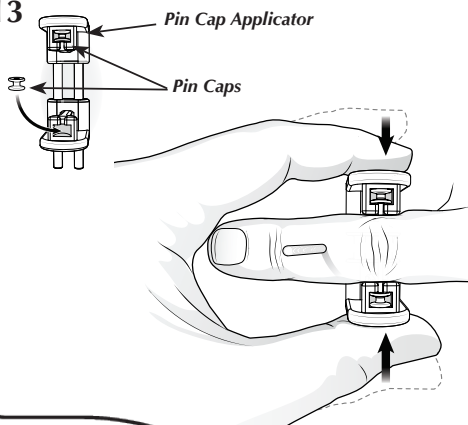

Place the Pin Caps into the cavities of the Pin Cap Applicator. Ensure that the holes in the Pin Caps face each other.

Align the slots in the Pin Cap Applicator with both ends of the Transverse Pin and squeeze the Pin Cap Applicator together, clamping the Transverse Pin between the Pin Caps.

Continue to squeeze the Applicator until both Pin Caps are firmly pressed onto the tips of the Transverse Pin. Confirm the Pin is completely inserted into the Pin Caps with an A/P fluoroscopic view. (See below.)



14

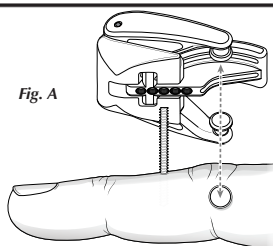

Place the Dorsal Pin into one of the holes in the underside of the **PIP Fix**. The device slides over the threads; there is no need to rotate the device onto the pin (Fig. A).

Choose a hole that positions the Elastic Band Posts directly dorsal to the Pin Caps.

15

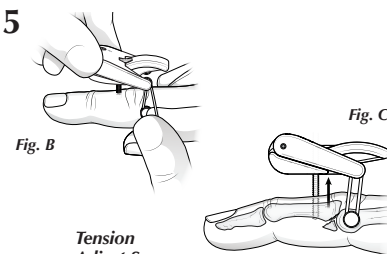

Pre-stretch the Elastic Bands prior to application. Install one Elastic Band between the Elastic Band Posts and the Pin Caps on each side of the finger. (Fig. B)

Recurrent joint subluxation or dislocation may occur after the PPG is removed even with the bands installed (Fig. C).

Use longitudinal traction to the fingertip to help realign the joint. Evaluate if the initial Elastic Band tension is sufficient to maintain joint reduction. If not, reapply manual traction while increasing the Elastic Band tension by rotating the Tension Adjust Screw (Fig. D).

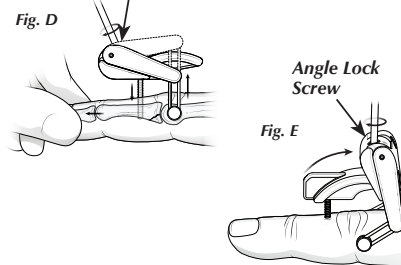

If length restoration is required, use the Hex Wrench to loosen the Angle Lock Screw and manually slide the body of the device proximally along the arc to a point where the desired angle of the Elastic Bands is reached. Re-tighten the Angle Lock Screw to hold the device in this position (Fig. E).

16

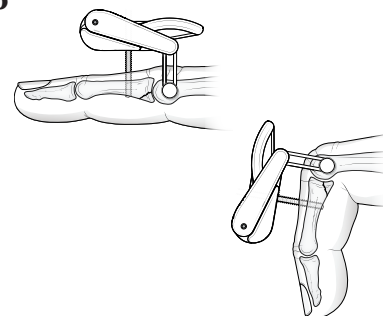

For tips on band tension adjustment see the back of this Condensed Surgical Guide.

The optimal reduction force is evaluated by fluoroscopic x-rays including flexion and extension lateral views. **Use the least force necessary to maintain joint reduction.**

A reasonable arc of active and passive PIP joint motion should be possible. Lateral fluoroscopic views with the patient actively flexing and extending the finger are optimal in judging the ability of the **PIP Fix** to maintain concentric joint reduction.



Hand Biomechanics Lab

77 Scripps Drive, Suite 104 Sacramento, CA 95825 (800) 522-5778  
© 2007-2018

## Dorsal Pin Installation

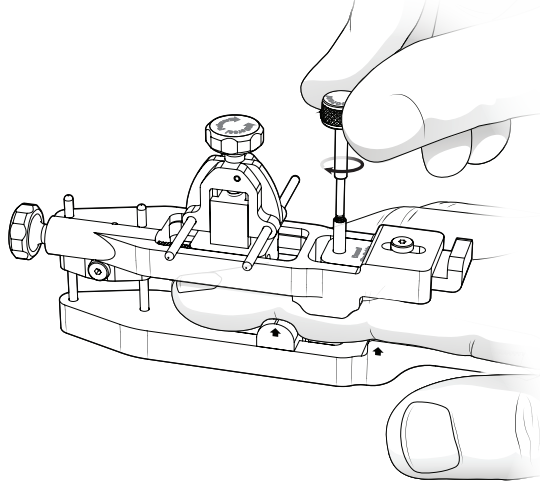

1 rotation of pin knob = 0.6 mm  
 10 rotations of pin knob = 6 mm  
 1.7 turns of pin knob = 1 mm

## Transverse Pin Guide Adjustment

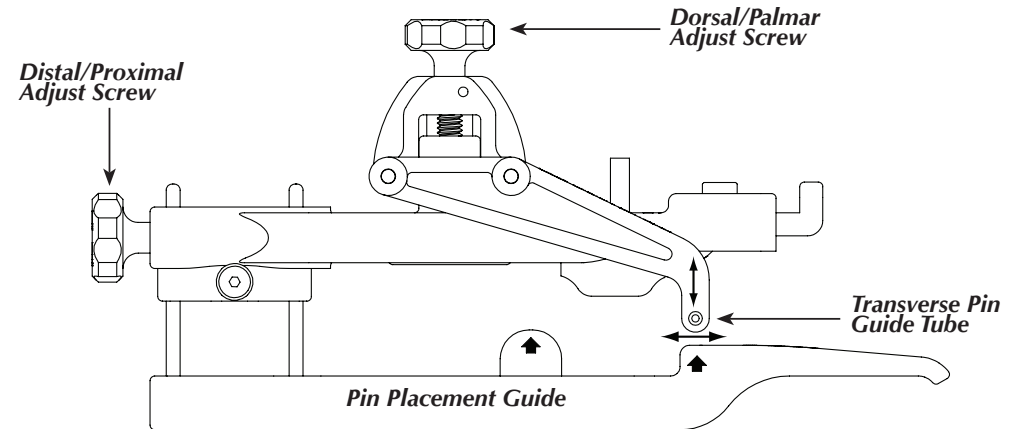

1 rotation of Adjust Screw = 0.8 mm  
 10 rotations of Adjust Screw = 8 mm

## Elastic Band Adjustment

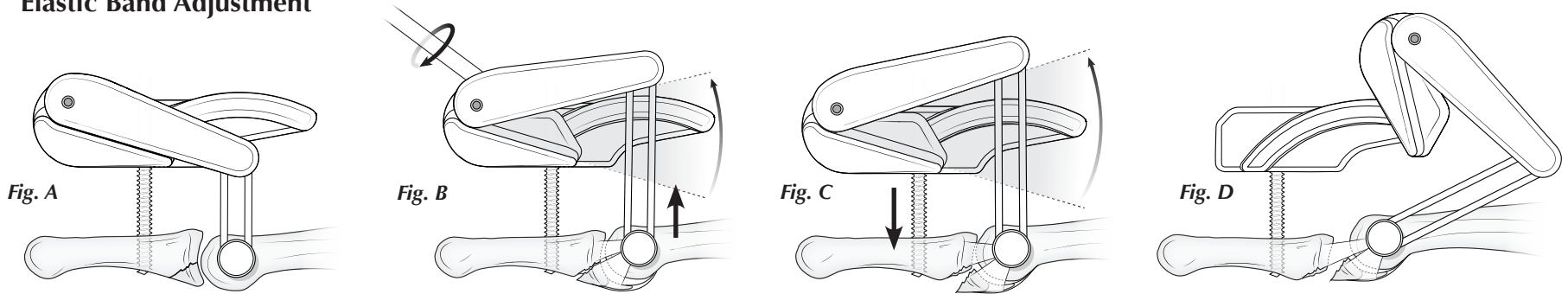

**Fig. A.** If the tension produced by installation of the Elastic Bands is enough to reduce the joint, no increase in band tension is required.

**Fig. B.** Increasing the tension beyond what is needed to reduce the joint puts a strain on the collateral ligaments. This may not be immediately apparent.

**Fig. C.** Over time, excessive translating force can damage the ligaments and may result in a volar subluxation or dislocation of the joint.

**Fig. D.** Over time, excessive length restoration force can produce additional capsular elongation and may overdistract the joint or create a volar subluxation or dislocation of the joint.

**Do not increase band tension beyond what is necessary to obtain joint reduction.**